

## Speed and Flexibility

# FPGA

For applications with extremely short latencies and cycle times

Tougher laws on emissions and fuel consumption make new drive concepts with highly sophisticated sensor systems a necessity. This also affects rapid control prototyping (RCP) and hardware-in-the-loop (HIL) simulation. To help meet these tougher requirements, dSPACE has produced its new DS5203 FPGA Board. Installed directly on the I/O interface, the board can be programmed any way you like. It is an invaluable assistant that not only performs signal conditioning, but also calculates models that require high dynamics.

### FPGAs for Versatility

Field-programmable gate arrays (FPGAs) are programmable logic circuits. Essentially, they are programmed by combining and connecting their logic elements and memory cells in many different ways. Each logic element consists of a programmable truth table (look-up table, LUT) with 4-6 inputs, one output, and one flip-flop (1-bit register) for directly representing simple logical operations (AND, OR, etc.) To implement complex digital signal processing algorithms such as FFTs or even entire embedded microcontroller cores, several logic elements are used together.

The FPGA architecture supports genuine parallel processing, achieved by inserting hardware blocks multiple times. The hardware functions, and their interconnections via the FPGA's logic cells, are described in a hardware description language such as VHDL. This allows an FPGA's behavior to be described in text form without its structure having to be known. The FPGA

manufacturer supplies a tool called a synthesis tool that generates the FPGA's actual configuration.

### Graphical Programming: Straight from Simulink® Model to FPGA

The most convenient way to configure an FPGA is graphical modeling, for instance with the Xilinx® System Generator (XSG), a Simulink® blockset for configuring Xilinx FPGAs. The XSG contains simple logic elements and complex blocks such as Fourier transforms and FIR filters. dSPACE provides both the hardware (DS5203 FPGA Board) and the software (RTI FPGA Programming Blockset) to connect the XSG models to the FPGA's interfaces.

The DS5203 FPGA Board contains a programmable Virtex® 5 Xilinx FPGA and preconfigured I/O driver components. The RTI FPGA Programming Blockset is a convenient way to connect the I/O board's I/O driver components and to model the connection to a processor board, so processor boards (such as dSPACE's DS1006 used as the central board

for calculating complex models) can be connected to the FPGA quickly and simply. Thus, FPGA programming is seamlessly integrated into the Simulink environment, which the user already knows from working with dSPACE's prototyping or hardware-in-the-loop systems. When the FPGA board is used, the synthesis, build, and programming of the FPGA or processor can be run directly from Simulink for optimal convenience.

### Further Requirements for Programming

In the synthesis process, each function and each model block is individually mapped to dedicated hardware and requires space on the FPGA. Since floating-point data types consume an extremely high amount of resources, only operators for fixed-point data types can be run usefully on today's FPGAs. To achieve a reasonable compromise between precision and space requirement, it helps when an FPGA expert supports the model developer in defining the bit widths of different functions. The FPGA expert also helps in optimizing FPGA-specific properties such as signal execution times and the timing of switching. Offline simulation or joint simulation of the Simulink model and the VHDL code helps developers identify any problems before implementation on the actual FPGA.

Because of these requirements, an FPGA expert will probably support the software developer responsible for modeling if a function has to be implemented on an FPGA. Either the two of them work together and run joint simulations of their intermediate results, or the FPGA expert solves the FPGA tasks first and then passes the solution on to the soft-

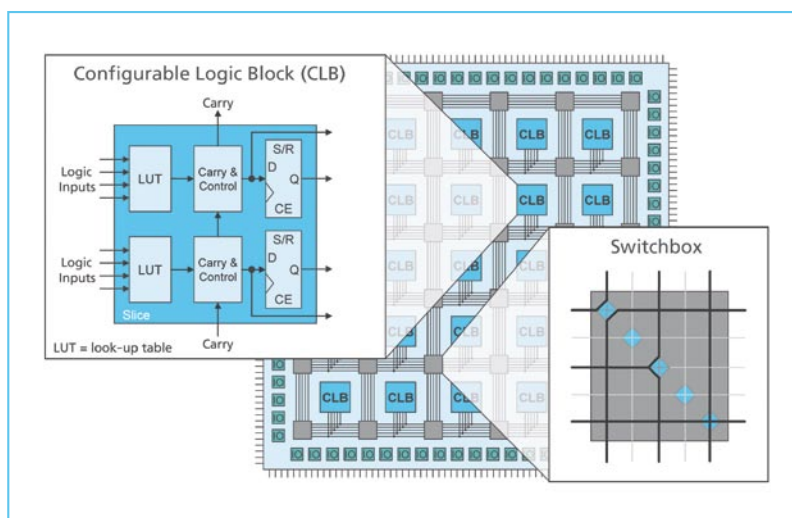

*Field-programmable gate arrays (FPGAs) consist of a large number of logic elements that can be interconnected flexibly. This makes FPGAs useful for an extremely wide range of applications.*

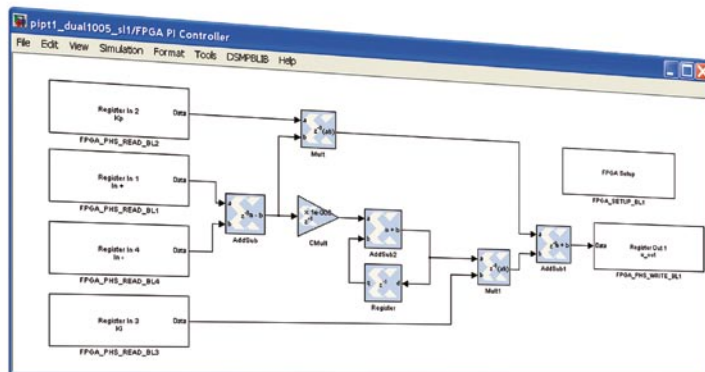

Simulink model with XSG blocks for the DS5203 FPGA Board: a PI controller as an example.

ware developer. The result is a growing pool of solutions that can be reused for future tasks.

### FPGAs in Use

The core of a dSPACE system is the processor board. If the processor board cannot calculate a model in the necessary cycle time, a part of the model has to be moved out to an FPGA.

Even though an FPGA has a considerably slower clock rate (the DS5203 has 100 MHz) than a processor (the DS1006 Processor Board has 3 GHz), it can solve numerous tasks faster. This is because its logic elements work in parallel, and this often more than compensates for the lower clock rate. Moreover, the FPGA on the DS5203 is connected to the I/O directly, so the entire bandwidth of converters can be used with minimum latencies, and very fast control loops can be implemented. This is increasingly an issue in the development of automotive ECUs, which always have more requirements for fast, complex, and highly reactive control circuits for reducing emissions and consumption. Cylinder pressure-based control and knock analysis,

for example, are two applications fields that demand powerful signal conditioning. The potential of an FPGA is ideal for these.

### Great Advantages for Electrified Powertrains

Powertrain electrification is fast gaining ground as a means to reduce fuel consumption. Mechanically coupled auxiliary aggregates (such as hydraulics and cooling water pumps) are being replaced by electrical aggregates that run as and when required and need no energy otherwise. To develop controllers for these electric drives, different interfaces need to be served flexibly. They include interfaces for position

sensors such as resolvers and encoders, and also for addressing power stages for block and sine commutation. When ECU tests are run on an HIL simulator, parts of the electric drive model have to be implemented on the FPGA. Otherwise, the high dynamics requirements cannot be met. In electric drives, the ECU controls the power flow directly, usually at 20 kHz. Modeling the highly dynamic effects at the power stages with sufficient precision requires cycle times considerably lower than one microsecond. This can only be achieved by using FPGAs, with at least the motor current calculation running on an FPGA board.

### Technical Details of the DS5203

In contrast to the DS5202 FPGA Base Board, which provides an I/O configuration that is precisely tailored to a specific application, the new DS5203 is freely programmable and can be flexibly adjusted to a wide range of different scenarios.

The DS5203 has a very powerful FPGA, the Xilinx Virtex-5 SX95 FPGA, with 94,298 logic cells and 640 special DSP blocks. The DSP blocks include fast, resource-saving multiplication of two signals.

For connecting external sensors and actuators, the DS5203 provides 6 ADC,



The new DS5203 FPGA Board.

## Profile of the DS5203

Type:	FPGA board freely programmable via Simulink blockset
FPGA:	Xilinx Virtex-5 SX95, 100 MHz
I/O:	6 ADC, 6 DAC (14-bit, 10 MSPC), and 16 digital channels, extendable
Bus:	dSPACE PHS++

6 DAC (14-bit, 10 MSPS), and 16 digital I/O channels. The number of I/O channels can be increased by a plug-on module if required. Connection to the processor board is done as usual via the PHS bus.

The FPGA's 100-MHz clock rate lets even demanding tasks be implemented with very short cycle times. ■

## Summary

Programming the DS5203 FPGA Board with the RTI FPGA Programming Blockset and the Xilinx System Generator is a good way to consistently develop a processor application and an FPGA application together from Simulink. The interaction between the two applications can be tested in off-line simulation before they are loaded to the real-time system. Thus, users can react flexibly and quickly to tougher requirements - for example, for signal conditioning, using new interfaces, or speeding up model parts.

*Limited availability outside of Europe and Asia, please inquire.*

## Interview

With Jürgen Klahold,  
Product Engineer for Hard-  
ware-in-the-Loop Simulators,  
dSPACE GmbH



*Mr. Klahold, please tell us some typical applications for dSPACE's new DS5203 FPGA Board.*

With the electrification of power-trains, highly dynamic electric drives are being used in vehicles more often. Developing the necessary ECUs presents particular challenges, in prototyping and in HIL testing. The DS5203 provides the right solutions for this.

But it also opens up new potential for extended signal analyses, such as those needed for modern knock control.

*What functions can the DS5203 perform, especially in testing these applications?*

The high dynamics of electric drives demand simulation with a very short cycle time. If the effects of power stages also have to be included, cycle times far below one microsecond must be achieved. This is not possible unless at least a part of the controlled system's model – like the coil model – is moved out to an FPGA.

*What are the strengths and advantages of the board?*

The FPGA Board can be programmed directly from Simulink®, so it integrates seamlessly into the familiar tool chain. It has a powerful FPGA and extensive I/O interfaces on the actual board. If these are not enough, more interfaces can be added by means of a plug-on module.

*How do users benefit from using the board?*

Users can create applications that access the board's I/O directly and with virtually no latencies, so they can utilize the entire bandwidth of the signal converters. This lets them close control loops with very short cycle times, and also implement new interfaces.

*Thank you for talking to us, Mr. Klahold.*