

dSPACE

NEWS

FACTS · PROJECTS · EVENTS

Customers

BMW Tests Engine
Control Software with
dSPACE Simulator

Products

MotionDesk 1.2
Expands Your
Visualization World

**Boost Your Calibration Tasks
with the dSPACE Calibration System**



Editorial

- 3** by Dr. Herbert Hanselmann
President and CEO

Customers

- 4** TRW: Heading for the Future
with Steer-by-Wire
- 6** Active Control Retractor
with TargetLink at TRW
- 8** BMW: Testing Engine
Control Software

Products

- 10** The dSPACE Calibration System
- 12** New: RTI FlexRay Blockset
- 13** New: MotionDesk 1.2
Lights...Camera...Action!

Business

- 14** dSPACE in Space
- 15** Your Click to dSPACE
- 15** New Catalog 2003 and Demo CD
- 16** A Great Success –
German User Conference
- 18** Third User Conference
in Japan

dSPACE NEWS

dSPACE NEWS is published periodically by:

dSPACE GmbH · Technologiepark 25
33100 Paderborn · Germany
Tel.: +49 52 51 1 63 80 · Fax: +49 52 51 6 65 29
info@dSPACE.de · support@dSPACE.de
www.dSPACE.de

Editor: Bettina Henking
Layout: Marei Schmiedeskamp, Beate Eckert, Ute Bergmann
dSPACE Contributors:
Robert Bevington, Günther Gruhn, Louise Hackett,
Herbert Hanselmann, Ralf Lieberwirth, Thomas Pöhlmann,
Gerhard Reiß, Christine Smith

© Copyright 1998-2003
All rights reserved. Reproduction of all or parts of this
publication is permitted provided the source is stated.

This publication and the contents hereof are subject to
change without notice.
Brand names or product names are trademarks or registered
trademarks of their respective companies and organizations.

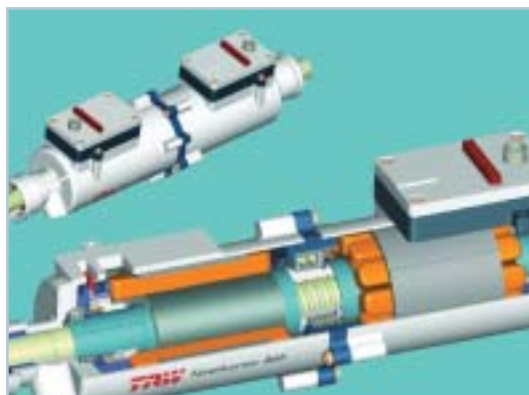

- 4** TRW Automotive is working on developing
steer-by-wire concepts for future generations of
production vehicles, using dSPACE Prototyper.



- 8** BMW uses several dSPACE Simulators to test
new software of complex engine controls. The test
systems have become a vital aid to putting new
engine control software into operation.



Have you bought a car loaded with electronics recently? If yes, you may be able to tell your own story about interesting „special effects“ and annoying trips to the repair shop. Or a trip in the cabin of a tow truck maybe. I could tell you a little story myself.

Indeed, as trouble report surveys have shown, electronics and its software already are a major source of car trouble. These statistics don't show the additional trouble the car manufacturers have before production launch. Thanks to hardware-in-the-loop simulators for system integration, the majority of problems are caught and remedied before the start of production. Sometimes the remedy is to disable the newly developed software feature. Not quite what it should be. And with warranty costs so high, management cannot overlook the problems. What is going on here? It seems that the complexity of new electronic systems is overtaxing the processes and tools that are in place at car manufacturers, at suppliers, and between both. While advanced tools and processes exist for certain tasks in many companies, they obviously are not yet used widely

enough, and are incomplete. Some systems are still developed on the basis of vague requirements and without higher abstraction level tools.

As a tool supplier I've felt for quite some time now that quite a bit of what the industry really needs is beyond that provided by present day tool chains, and the tool chains do not develop fast enough. Every control engineer knows what rise time and overshoot is. For the introduction of electronics in cars it seems to me that the rise time was too short and now we are in the overshoot phase. What would the controller do in that case? Reduce the control signal. And exactly that seems to be happening. Car manufacturers talk about slowing down the introduction of new systems. New systems will only be introduced if they deliver significant benefits that are visible to the end customer, or if laws dictate them. Consolidation is the order of the day. For us, this in no way means slowdown. We continue to invest in improving the tool chain and bringing it closer to where it should be.

The dSPACE Calibration System is another step in this direction. Our calibration tool, which is to be released mid-2003, supports all stages of the development process. Find out more about it in the detailed article of this dSPACE NEWS issue.

*Dr. Herbert Hanselmann
President and CEO*



10 *The launch of the dSPACE Calibration System will help you meet future calibration challenges. Its modular hardware and software concept facilitates tailor-made and cost-effective*

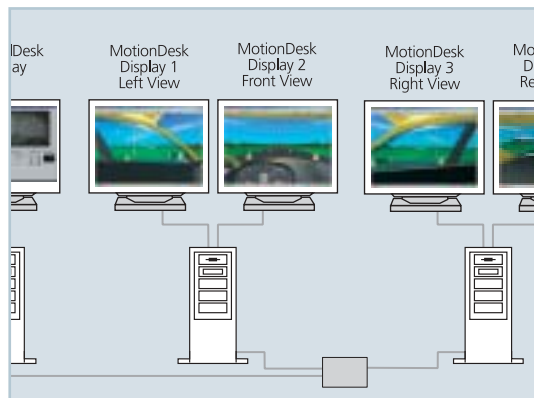

13 *Lights... Camera... Action! MotionDesk is the best in its class for 3-D visualization of real-time experiments. Further improvements are soon to be available in MotionDesk 1.2.*

TRW: Heading for the Future with Steer-by-Wire

- **Steer-by-wire systems for passenger vehicles**
- **Algorithm development with dSPACE Prototyper**
- **TRW Automotive working on production-intent solutions**

As the world's leading supplier of steering systems for passenger vehicles, TRW Automotive is already working on developing steer-by-wire concepts for future generations of production vehicles. Using dSPACE Prototyper meant that only a short time was required to develop all the essential functions of a steer-by-wire prototype system on a component-in-the-loop test bench and map them in a test vehicle.

Unlike the hydraulic or electric servo steering systems in use today, steer-by-wire systems use an electronically controlled actuator to convert movement of the steering wheel into front wheel movements. So that the driver has the 'feel' of steering, feedback on the lateral forces is provided by a force feedback actuator connected to the steering wheel.

System Architecture: Fail-Safe or Fault-Tolerant

Steer-by-wire systems can be either fail-safe or fault-tolerant. Fail-safe systems have an independent mechanical backup system. The electronic control in such systems can take the form of a fail silent unit (FSU). In other words, system safety is sufficiently guaranteed if the electronics have a fault recognition mechanism that reliably ensures automatic shutdown when a fault occurs.

A fault-tolerant system architecture, on the other hand, is based on distributing the hardware across several redundant subsystems to ensure that system

functions are maintained. The subsystems have their own electronic control units (ECUs) and are networked via a real-time-capable, fault-tolerant data bus.



▲ *Steer-by-wire front axle actuator.*

Pre-Prototype with a Fail-Safe System Architecture

Recently, many automotive manufacturers and suppliers have come to regard fault-tolerant systems as the future of steer-by-wire. It is now a major field within steer-by-wire development. However, it is just as important to choose the right hardware components for the sensor and actuator systems and the ECUs. These hardware components have to perform their tasks largely independently of later integration into a fault-tolerant system architecture, so they can also be tested independently in the early phases. The same applies to the software algorithms that define the dynamic transmission behavior of the steering system and the feel of steering. So to cut the development time until the first prototypes are implemented, at TRW we decided to first set up a pre-prototype system for a steer-by-wire application with an electromagnetic clutch in the steering column. The system control was designed to be 'fail silent'. This means that the pre-prototype has a fail-safe system architecture. From the beginning, however, all the hardware components

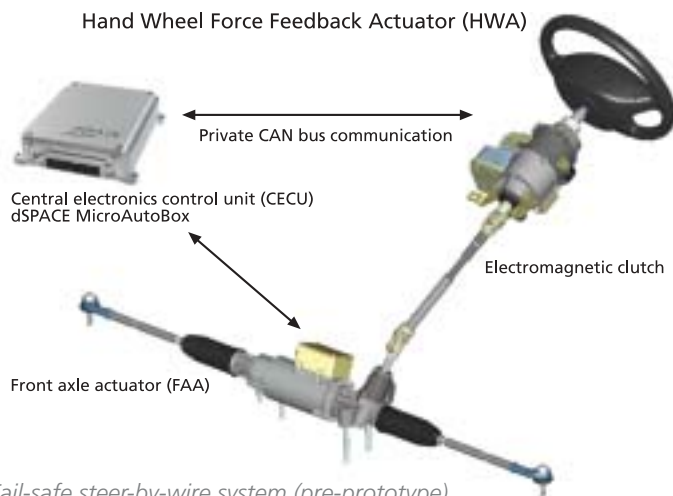

▲ *Fail-safe steer-by-wire system (pre-prototype).*

in the pre-prototype, except the central ECU, were selected with a view to producing a fault-tolerant system. In the pre-prototype, dSPACE's MicroAutoBox performs the tasks of the central ECU.

From Component-in-the-Loop (CIL) Simulation to the Test Vehicle

Three core areas were vital in the development of the pre-prototype system software:

- Higher-level steer-by-wire system functions (for example, variable steering ratio and force feedback characteristics at the steering wheel)
- Lower-level position control circuit for the front axle actuator and lower-level torque control circuit for the steering wheel actuator
- Sequence control and safety logic for system initialization and for switching between manual steering and steer-by-wire mode.

The algorithms for the higher-level system functions and the lower-level actuator control circuits were first represented in MATLAB®/Simulink® and then tested and optimized by offline simulation of the steer-by-wire system. The control of the steering wheel actuator is vital to the feel of steering. Right from the start of software development, we optimized the feel by using a CIL environment that includes the steering wheel actuator in the simulation to allow a subjective evaluation of the steering process.

This was done by connecting the integrated ECU of the steering wheel actuator to a dSPACE signal processor via a high-speed CAN bus. This enables the reference values for response torques at the steering wheel to be determined by means of a real-time-capable vehicle dynamics simulation model (ve-DYNA). Parallel to that, we also visualized the vehicle responses to steering wheel inputs with an on-screen dSPACE 3-D animation. The sequence control for the pre-prototype system was represented with MATLAB/Simulink/Stateflow and also first tested via offline simulation. To try out the pre-prototype in a test vehicle, the algorithms for the system function and the sequence control were finally implemented on dSPACE's MicroAutoBox. Just as we did with the CIL test bench, we also used dSPACE's ControlDesk in the test vehicle so that we could easily adjust parameters and acquire measurement data. Taking the results from the pre-prototype development as our basis, we are currently working on the next development stage, a production-close steer-by-wire prototype with a fault-tolerant system architecture. From our present point of view, the first steer-by-wire launch could be in 2007. However, we do not anticipate going into large-scale production until 2010.

*Dr. Heinz-Dieter Heitzer
TRW Automotive
Germany*

▼ CIL test bench with force feedback actuator.



Active Control Retractor with TargetLink at TRW

- TargetLink production code for the vehicle dynamics functionality
- TargetLink, the easy-to-use development environment
- Integration of the software module after only four weeks

TRW has developed a reversible belt pretensioner that gives the driver and other vehicle occupants enhanced protection compared with conventional seat belt systems. When vehicle dynamics become critical, the seat belt is pretensioned by an electric motor. The project took only 18 months to develop and successfully used TargetLink to generate production code for the entire vehicle dynamics part.

New Belt Pretensioner – Proactive and Reversible

Present-day belt retractors are usually triggered pyrotechnically by the airbag ECU (electronic control unit) during a collision. Such systems are irreversible and only leap into action *after* a crash. In future, vehicle occupants will be protected *before* a crash occurs, in the pre-crash phase, whenever a critical situation is assessed on the basis of vehicle dynamics. The system uses an electric motor to minimize belt slack. This gives occupants firmer restraint. If the crash is avoided, and vehicle dynamics have restabilized, the belts are automatically loosened and the reversible belt pretensioner is immediately ready for action again. If a collision does occur, the vehicle's occupants are already held firmly in position, which considerably improves the effectiveness of the other safety systems.

How It Works

The electric motor works on the belt roller to tighten the belt. The motor is activated by an ECU. This receives data on the current vehicle dynamics via the CAN bus, evaluates the data and if necessary tells the electric motor to tighten or loosen the belt. The vehicle dynamics functionality that forms part of the ECU processes a total of 14 input signals to produce 11 computed output values.

TargetLink generated the production code for this part of the ECU, which amounts to around 20% of the overall functionality including all utilities and drivers.

Why TargetLink?

The customer already had the functions for evaluating vehicle dynamics in the form of a MATLAB®/Simulink® model. TargetLink was ideal in this situation, because it could create and integrate the vehicle dynamics software model straight from MATLAB/Simulink. Developers became familiar with TargetLink's easy-to-use development environment quickly, resulting in faster implementation and verification of the specification. Module testing was carried out completely on an evaluation board. This meant that we could assure the quality of the production code very early on. TargetLink's documentation features meant that no further documentation work on the production code was needed. Thus, in addition to the time saved, the quality of the documentation was also improved as regards being up-to-date and code-consistent.

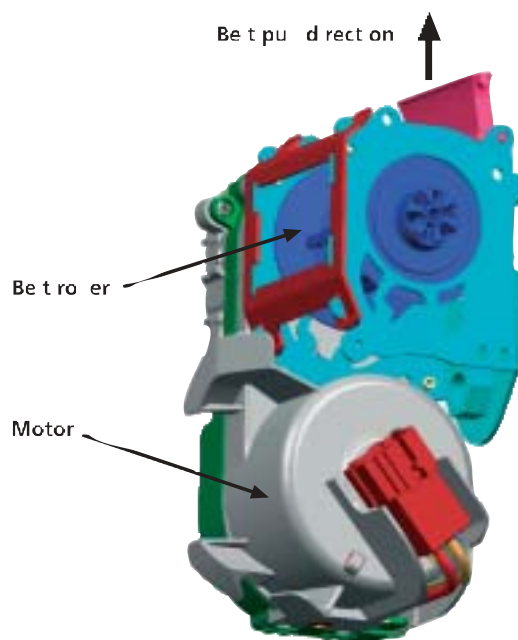

◀ TRW's reversible belt retractor.

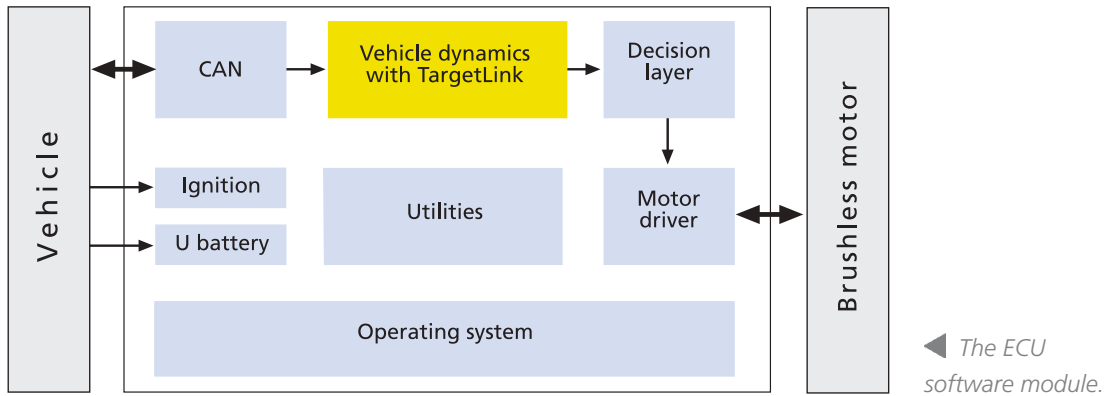

Integrating TargetLink into Our Development Environment

To begin, we acquired TargetLink Base Suite, Target Simulation Module and an evaluation board. After installing these tools, we adapted the Target Simulation Module to the compiler we were using, and created interfaces to the software project. When the Simulink models were converted into TargetLink models, special library functions were also created. Further steps included specifying the maximum stack size and the maximum computing time, and defining the variable types and their scaling. The code generation, testing and model optimization processes were then run iteratively until all the requirements had been met. After only four weeks of putting TargetLink into action, we were able to integrate the finished vehicle dynamics software module into the project.

Particular Challenges

Increasing complexity and stiffer requirements regarding computing precision made it necessary to develop the vehicle dynamics model further.

We also had to adapt it to the microprocessor resources, to meet constraints such as stack size and computing time. One example of how we did this was by optimizing the data flow to eliminate 64-bit operations. More resources were freed by changing the representation of the parameters and variables from arbitrary to a power of two.

Outlook

TargetLink was the right choice. The software module we produced will be integrated into future product applications and existing modules will be implemented using TargetLink. We also plan to use TargetLink to generate production code from Stateflow.

*Ega Tschiskale
TRW Automotive
Electronic Control Systems
Electrical Drives Department
Head of Hardware\System
Germany*

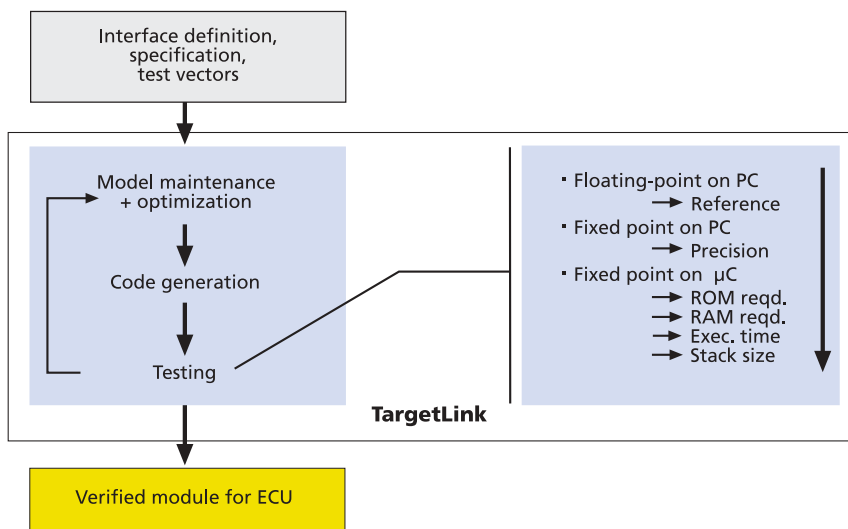

◀ Module test with TargetLink.

BMW: Testing Engine Control Software

- **New software tested systematically before actual use**
- **A diverse range of engine control projects**
- **Three identical simulators for a wide range of applications**

To test the software of complex engine controls, entries to the fault memory of the electronic control unit (ECU) must be prevented. In addition, almost all control loops have to be closed to allow self-diagnostics. This is only possible by means of hardware-in-the-loop simulation. So BMW uses several dSPACE Simulators to test new software. The test systems have become a vital aid to putting new engine control software into operation at BMW.

Engine Control Projects at BMW

Our department at BMW is responsible for hardware and software development in the field of engine control. We handle a diverse range of engine control projects and place great importance on close cooperation between function development and calibration teams, particularly for functions with BMW know-how such as VALVETRONIC in the BMW 3 and 7 series. In most projects, the software is developed jointly by ourselves and an ECU supplier, who provides the hardware and appropriate basic software. Our modules are then integrated into the software. BMW has always used software programming and debugging systems for troubleshooting and quality assurance. Every developer had his or her own test system for testing engine control by simulation. The tests were not complete. For example, we could not create closed control loops or adjust signals plausibly to one another, nor could we override the ECU's monitoring functions, which protect the engine. Moreover, the systems were BMW's own in-house developments that we supported in parallel to the software, which meant a considerable workload

for us. Changing to a standardized hardware-in-the-loop system was an obvious next step.

The Change to dSPACE Simulator

We opted for dSPACE Simulator. This allows us to perform flexible engine simulations for a wide range of engine control projects and ECUs, from single-cylinder to twelve-cylinder engines. All the control loops are now closed, and operating points such as idling mode can be set stably.

The basic hardware of our dSPACE Simulators consists of a DS1005 PPC Board for model computation and two DS2210 HIL I/O Boards for generating and capturing I/O signals. The hardware is standardized and can be extended flexibly, which enables us to use several identical systems. The throttle valve and the engine immobilizer are integrated as real loads. Various cable harnesses and ECU connectors are available for different projects. This means that we can switch from one engine control project to another with relatively little effort.

Projects Run Smoothly

The setting up of the systems ran smoothly. The specification was produced by means of ECU requirement specs and the requirements of our software developers. dSPACE did all the designing, planning and assembly work.

We used en-DYNA from TESIS in Munich, Germany, as the engine model. Thanks to the excellent integration properties of MATLAB®/Simulink® models, we were easily able to reuse our BMW submodels and port them to the system. New engine models were parameterized by TESIS, based on our own test bench measurements.



► *BMW engines – the engine control software is systematically tested with dSPACE Simulator.*

© BMW AG

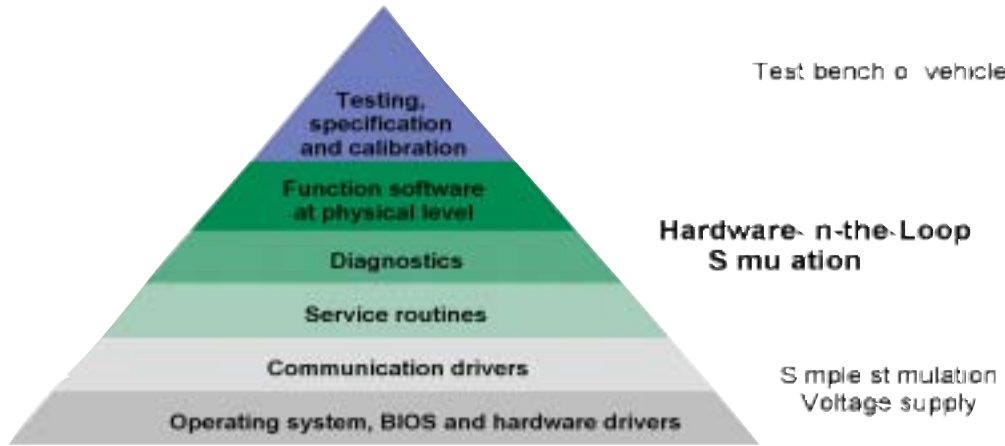

▲ Hardware-in-the-loop simulation is being applied for many different software types at BMW.

The software was put into operation on a production-ready ECU, and the anticipated results were verified. After this success, there was nothing to stop us duplicating the dSPACE Simulator and equipping our developers with it.

Our department has been using dSPACE Simulators since February 2002, and they have so far been used successfully in three different engine control projects. The main focus is on the following tasks:

- Verification of software at functional level, mostly without reference to complex physical conditions
- Testing of arithmetic operations
- Testing of injection and ignition timing and synchronization of crankshaft and camshaft
- Performing initial calibration
- Testing diagnostic functions

Established Position in the Development Process

It is not our intention to replace verification entirely with dSPACE Simulator. Final verification of the code and checking of the specification will always be performed on a real engine, since it is not possible to assess drivability on a simulator. However, dSPACE Simulator is a very important aid to implementing new software. Function software is particularly suitable for testing by simulator. Before new program versions are put into use, they are always checked on the simulator. For example, the engine model can be used to check ignition and injection timing "safely".

When creating and testing the software, we partly perform initial calibration of functions, feeding data to constants and 1-D and 2-D look-up tables. In addition, by connecting the simulator to the measurement and calibration system by means of ASAP3 (ASAM-MCD 3MC), we can compare internal engine control variables and model variables. However, complete test automation is difficult to achieve, as the behavior of the engine control depends on too many input variables. Nevertheless, dSPACE Simulator provides excellent features for test automation and the reproducibility of test cases. We have since started automated testing of specific basic engine control functionalities, such as analog value capture, power-up/power-down behavior, and communication. All the tests that are performed are documented automatically for the purpose of quality assurance.

The use of simulators extends the potential for testing complex engine control software without a vehicle or engine. Many of the test steps we can now perform were very difficult or even impossible with the old systems. This considerably improves the quality of the software before it is run in the vehicle or on a test bench, meaning that verification in the vehicle is faster and more efficient. dSPACE Simulators have fast become an essential component in our development process.

*Marcus Engelke
BMW AG
Germany*

The dSPACE Calibration System

- Intuitive and easy to use
- Tailor-made solutions for a great variety of scenarios
- Simple to integrate into existing development processes
- Launch planned for mid-2003

Parameter calibration plays a major role in the overall development process for electronic control units (ECUs). To reduce the time to market for innovations despite the growing complexity of ECU software, developers need well-designed tools that give optimum support to calibration. To help you meet the calibration challenges of the future, dSPACE will be launching the dSPACE Calibration System in mid-2003.

Modular Concept

With its scalable hardware solutions, the dSPACE Calibration System offers you cost-effective solutions for your calibration and measurement tasks. Almost any combination of calibration interfaces can be connected to the host PC, for example, memory emulators and XCP on CAN, I/O modules or CAN interfaces. Connection to the host PC can be either direct or via the dSPACE Calibration Hub. The number of interfaces can be increased simply by cascading several Calibration Hubs. Thus, the system guarantees maximum flexibility.

Calibration Interfaces

The dSPACE Calibration System will provide several interfaces for calibration. The generic memory emulator (GME) from dSPACE is very versatile, supporting a wide range of microcontrollers and ECUs. Adjustment to the ECU is by means of a Target Adapter, which connects the ECU signals to the GME. This concept provides our customers with the optimum solution in terms of cost and time, as new ECUs can be adapted to the GME quickly, and

the GME itself can be reused in different projects. Thanks to their compact size, the combination of memory emulator and Target Adapter can be installed in almost any ECU. Alternatively, the GME can be mounted on the ECU in a separate housing.

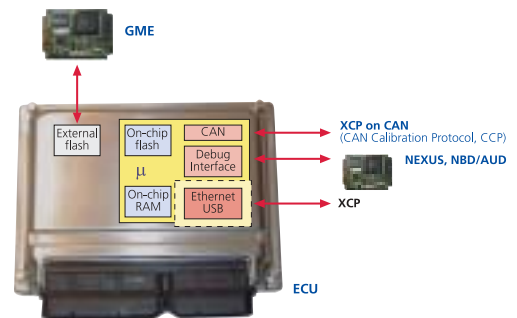

▲ Overview of calibration interfaces.

The GME is a completely independent system and can be connected to the host PC directly via USB. To fulfill vehicle safety requirements, we implemented a special USB communication protocol with error detection and correction and developed a USB opto-isolation. A data buffer several megabytes in size saves data in case the USB connection is temporarily interrupted. There is also an on-board flash memory that saves the current software settings, even if the power supply fails.

To support calibration via XCP on CAN, dSPACE will offer its own XCP service for implementation on ECUs. Further XCP implementations, such as XCP on USB, are planned for the future.

The trend in processor architectures is to reduce the number of access options via the external data and address bus, and calibration via debug interfaces like NEXUS or NBD/AUD will increasingly be the focus of attention. The dSPACE Calibration System will in future also provide appropriate calibration interfaces for these.

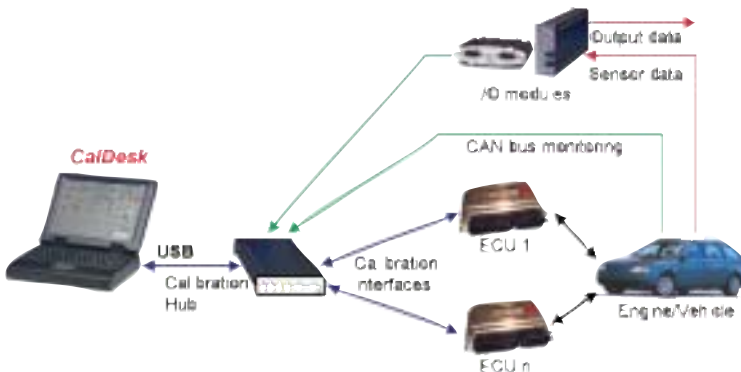

▲ The flexible hardware concept of the dSPACE Calibration System.

Calibration Software: CalDesk

In developing the dSPACE Calibration System, we are working closely with customers from the automotive sector so we can provide everything that developers look for in a modern-day experiment user interface. CalDesk, dSPACE's calibration software, has wizard and template mechanisms that will make tasks

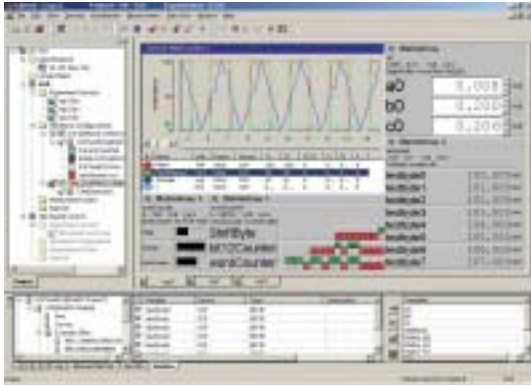

▲ CalDesk has an intuitive user interface.

easier. For example, there are XML templates that can be used to automatically generate the entire folder structure of a project, including a variety of basic settings. Thus, during the actual calibration task, the files containing measurement values, parameters and reports are automatically placed in the correct folders. This relieves engineers of a lot of administrative workload, giving them more time for the experiment itself.

Parallel to this, CalDesk offers complete flexibility for optimum adaptation to specific calibration scenarios. This includes being able to control the experiment completely by keyboard, user-definable shortcuts and audible signals when preset values are exceeded. There is also flexibility with the support of different ASAM-MCD standards. The integrated COM interface, based on the new ASAM-MCD 3MC specification, allows external access to CalDesk, for example, from MATLAB®, or Microsoft's Excel. The interface also allows continuous transmission of measurement data to higher-level parameter optimization or automation tools.

The dSPACE Data Dictionary

The dSPACE Data Dictionary is the central data container in the dSPACE tool chain, and therefore also for CalDesk. It contains all the data on settings and measurement variables on the ECU, CAN bus signals or external measurement channels that are relevant to calibration. The instruments can be automatically configured in CalDesk using the variable attributes from the dSPACE Data Dictionary, for example, units, value ranges and display color. This automatic configuration considerably reduces the workload involved in setting up new experiment interfaces. Moreover, CalDesk and the integrated dSPACE Data Dictionary are open to the integration of in-house data formats via an application programming interface (API), which facilitates installation in existing development environments.

Extension of the Tool Chain

The dSPACE Calibration System is a major addition to the dSPACE tool chain. It has an intuitive and easy-to-learn user interface that minimizes training time and ensures a high level of acceptance. The openness of the system with regard to in-house data formats, a variety of interfaces (including ASAM-MCD, COM) and different kinds of hardware ensures optimum integration into existing developing environments to produce tailor-made and cost-effective solutions.

INFO 001

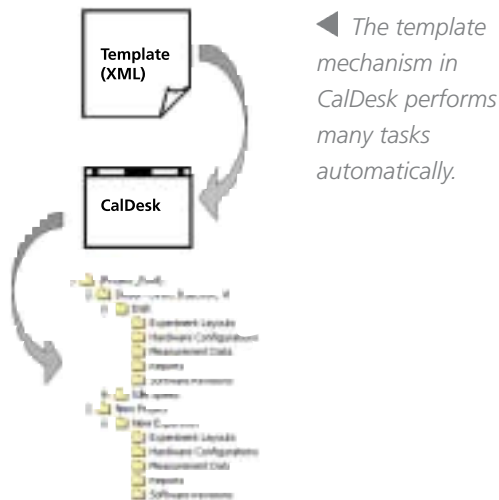

New: RTI FlexRay Blockset



Driving along the highway, you turn into a corner and suddenly there is nothing but tail lights ahead. The road is jammed. The brakes are slammed full on at 185 km/h. This is just one of the many potential road traffic situations that brake-by-wire systems must cope with in tomorrow's vehicles. For drivers to keep control over vehicles even in extreme situations, future x-by-wire systems will require an extremely safe, real-time-capable transfer protocol for their distributed control systems. FlexRay was developed especially for these tough requirements, offering a time-controlled, deterministic and fault-tolerant communication environment. The new RTI FlexRay Blockset, in conjunction with other tools from dSPACE and DECOMSYS (Vienna), provides a convenient method of function prototyping for such an environment.

INFO 02

The new RTI FlexRay Blockset will be available in the second quarter of 2003. It builds on the principles of Real-Time Interface (RTI) and has all the features necessary for code generation for dSPACE Prototyper in conjunction with FlexRay. A MATLAB®/Simulink® environment is used throughout all development steps, so developers are guaranteed seamless design support for function prototyping.

Function Prototyping with the RTI FlexRay Blockset

FlexRay's underlying time-controlled approach requires additional planning steps in the control design phase as compared to the familiar procedure. These extra steps are supported by a combination of dSPACE

to individual prototyping nodes by means of the RTI FlexRay Blockset. The behavior of the system with reference to the communication environment can also be observed in a Simulink simulation. Because all system components have a time relationship to one another, a model of the overall system is required. The automatic model separation, initiated by the RTI FlexRay Blockset, ensures that all the model parts required for prototyping are extracted, enabling code to be generated for dSPACE Prototyper. Code generation for the model functionality itself is performed by the RTI FlexRay Blockset, while the code for the communication environment is generated by a DECOMSYS tool. The real-time simulation can then be run on the dSPACE hardware. All the tasks and the communication are performed according to the schedules previously defined. The local time base of each prototyping node is synchronized to the global FlexRay time base.

► Modeling a FlexRay application with two hosts.

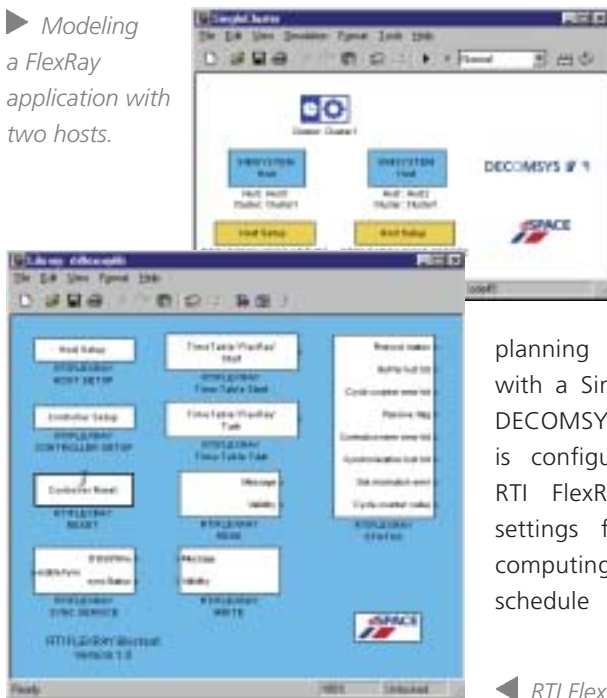

tools and special tools from our cooperation partner, DECOMSYS. For example, during the modeling phase all tasks and communication connections for the external planning tools are specified with a Simulink blockset from DECOMSYS. dSPACE Prototyper is configured with the new RTI FlexRay Blockset. These settings form the basis for computing a communication schedule and assigning tasks

FlexRay
FlexRay is a new, time-controlled communication protocol for safety-critical controls in vehicles. An event-controlled standard bus such as CAN reaches high transmission rates at low loads, but when a large number of bus events occur simultaneously, there are unpredictable transmission delays. However, safety-critical, real-time applications need the timing of bus events to be precisely predictable. The networked FlexRay controllers generate a global time base that makes all the signal execution times in fault-tolerant applications clearly definable and predictable.

◀ RTI FlexRay Blockset.

New: MotionDesk 1.2 Lights... Camera... Action!

MotionDesk is dSPACE's software for visualizing real-time experiments in a 3-D world. A 3-D environment makes it easier to analyze the critical behavior of simulated mechanical systems, such as driving or flight maneuvers. Even though MotionDesk is the best in its class, we had plenty of ideas for further improvements, which are soon to be available in MotionDesk 1.2.

In order to perform 3-D online animation, MotionDesk reads real-time data from a dSPACE system, typically from dSPACE Simulator. Based on this data, MotionDesk displays the animation of moving objects, like cars, robots or airplanes, in real time. Any changes that occur during simulation are immediately visible on the screen. What makes MotionDesk unique is its intuitive operation and, above all, the high quality and speed of the graphical display.

Do You Need Even Better Graphical Performance?

The graphical performance can be enhanced by using the "MotionDesk Multi-PC Interface Kit", a new extension to MotionDesk. The kit allows MotionDesk to run on a separate PC, which naturally improves the graphical performance. Typical applications are man-in-the-loop, in which a human driver controls a simulated car. Of course, the visual driver feedback has to be highly realistic. This requires a high frame rate and a low latency time. Such systems can now be set up with little effort.

In addition, the MotionDesk Multi-PC Interface Kit allows the visualization of the same MotionDesk experiment from different displays. Imagine a car simulator (see graphic): the most realistic impression

of the simulation occurs when the driver sees different perspectives of the scene, as if he were looking out of the various car windows.

The MotionDesk Multi-PC Interface Kit will be available as an add-on to MotionDesk 1.2 this spring.

Seamless Connection of Simulink Models

While real-time models in Simulink use state variables, 3-D animation requires a system with 6 degrees of freedom to determine on object's position and orientations.

The new MotionDesk Blockset provides Simulink blocks that allow you to prepare your Simulink real-time model for 3-D animation. This graphical form of programming makes the interconnections between the model and the 3-D objects extremely tangible. The MotionDesk Blockset is included in MotionDesk 1.1 and later.

Among other new features, MotionDesk now offers an improved driver camera with smooth follow behavior, sound generation for vehicle noises via ControlDesk, and a new 3-D Object Library Manager for effortless object import and coloring.

- 3-D online animation of simulated mechanical systems in real time
- Easy expansion for the highest graphical requirements
- PC-based Simulink simulation
- Sound generation for vehicle noises using ControlDesk

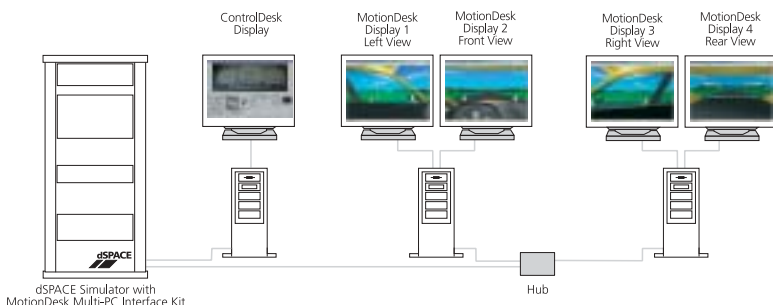

◀ Designing a car simulator display with the MotionDesk Multi-PC Interface Kit – with minimum hardware requirements.

dSPACE in Space

dSPACE Inc. recently participated in the World Space Congress (WSC) 2002, the largest space trade exhibition ever. More than 20,000 people took part in the multitude of Congress components. Topics included science, technology, infrastructure, missions and exploration, business and applications, legal and policy factors, education and history. The dSPACE booth attracted many visitors interested in information on reducing their development costs using new tools for control development.

Kevin Kott, president of dSPACE Inc., gave a presentation on the "Advances in Control Software Development" to members of the American Institute of Aeronautics and Astronautics (AIAA). He discussed rapid control prototyping and hardware-in-the-loop development for aerodynamics, propulsion, structures, flight dynamics and control applications, focusing on the use of dSPACE real-time systems in conjunction with popular control modeling tools.

WSC 2002 was hosted and organized by AIAA under the auspices of the U.S. National Academy of Sciences. The event took place October 10-19, 2002, at the George R. Brown Convention Center in Houston. For more information about WSC 2002, visit www.aiaa.org/WSC2002.



▲ Kevin Kott, president of dSPACE Inc., giving a presentation at the World Space Congress 2002, Houston.



▲ Interface for the SCRAMNet+ communication system.

SCRAMNet+ Interface

dSPACE extends its support for the aerospace market by releasing the newly-developed SCRAMNet+ interface. SCRAMNet+ is a widely used real-time communication technology for many different aerospace applications such as simulator networks and distributed real-time control systems.

With the new SCRAMNet+ interface hardware, dSPACE modular systems can be integrated into existing SCRAMNet+ networks. Powerful dSPACE systems can be used as the real-time platform of choice for distributed control systems where SCRAMNet+ is the decided node-to-node communication link.

- The SCRAMNet+ interface provides 1 MB of shared SCRAMNet+ memory directly accessible by the DS1005 processor board, with standard fiber-optic media connections.
- A Simulink blockset is provided with the board, which allows the user to configure and use the interface directly from a Simulink model.
- There is full support for all the standard features and options of SCRAMNet+, including extensive interrupt generation and handling capabilities.
- The SCRAMNet+ interface generates interrupts on each 32-bit location in the 1 MB memory space, and handles these independently. In a similar fashion, the user has control over all outgoing messages with respect to specifying interrupt bits, and can set override flags for both input and output.

Your Click to dSPACE



Since October 2002, dSPACE's Web site has a new look. The new site is equally attractive to experts and newcomers to dSPACE. Information is easier to find, and it is now also available in German, English and French. Usability and fast search-and-find were the main goals of the new Internet concept.

Our aim is to make the site as interesting and attractive as possible with new navigation for easy access. If you are new to dSPACE, it provides introductory information on our company and its products, and detailed information on the latest product developments. If you are a dSPACE customer, it is now easier for you to access the support section.

The site offers you plenty of opportunity to contact us and interact however you prefer. It also provides direct access to our subsidiaries in France, the United Kingdom and the USA, where you can find country-specific information.

The main task of our Web site is to provide the latest news on dSPACE. The site is updated every day so that our customers always have the information they require. The News box on the home page presents the latest product and application updates, events and so on.

Whether you are a newcomer to dSPACE or an expert on dSPACE products, are looking for information on our company or its products, or require assistance – the pages are quick to find and easy to open. Enjoy your visit to our new Web site.

- www.dspace.de
- www.dspaceinc.com
- www.dspace.ltd.uk
- www.dspace.fr



New Catalog and Demo CD

Our 2003 dSPACE Demo CD and Catalog are available now. On 248 pages, the new catalog provides not only product details, but also numerous explanations and technical background information. The catalog gives a good impression of our new products, for example, in the fields of FlexRay, LIN, ECU calibration and test automation.

In addition to the catalog, our new Demo CD features many audiovisual software demonstrations that give you an even deeper insight into the functions of the dSPACE tools. Just check the box on your response card to receive a dSPACE Demo CD and Catalog.



A Great Success – German User Conference

Around 150 participants came to the Liederhalle center in Stuttgart on October 9-10, 2002, to discuss their experiences with the wide range of applications using dSPACE systems. Fifteen speakers from our major customers, including Audi, BMW, DaimlerChrysler, Opel and TRW Automotive Electronics and Components, gave interesting insights into their development work – from the use of rapid prototyping for engine controls to hardware-in-the-loop tests for the entire vehicle electronics system.



▲ Participants packed the Schiller Room of the Liederhalle in Stuttgart, Germany, to hear the papers presented by dSPACE users.

Bypassing was one of the major topics on the first day of the conference. Following an introduction on the method and potential of bypassing, Dr. Ulrich Zoelch from BMW continued the theme in his paper, reporting on the development of a high-speed bypass with the aid of dSPACE – a method that is proven and established at BMW. Audi is also successfully using bypass technology, for example, to develop a fuel pressure control,

as described by Manfred Nerb. Bernd Heintel and Jens Ruh took up another of the conference's major themes by reporting on how DaimlerChrysler will integrate future x-by-wire systems into a seamless development process with the support of dSPACE.

In the afternoon customers presented their projects from the field of hardware-in-the-loop simulation. From efficient testing of engine control functions at BMW (Marcus Engelke) to the automated

– and therefore extremely time-saving – testing of networked ECUs in car body electronics at Opel (Dr. Daniel Lemp) and right through to the simulation of air-conditioning ECUs in the development process at Behr-Hella Thermocontrol (Dr. Ralph Trapp), the authors provided fascinating insights into a variety of applications.



▲ Judging by the number of questions and opinions contributed by the audience, there is immense interest in other companies' development work.

V-cycle: The Big Picture

The agenda on the second day of the conference provided plenty of variety. The enormous diversity of applications for the TargetLink production code generator was once more evident: Ega Tschiskale from TRW used TargetLink to implement the vehicle dynamics software component for the new reversible seat belt retractor. Stefan Teuchert described how MAN is successfully using TargetLink and dSPACE Simulator in the development of the CCRT exhaust reduction system. Another paper from DaimlerChrysler concluded that the company is successfully using



► Demo systems at the conference exhibition displayed the latest developments from dSPACE and its cooperation partners.

TargetLink code generation in production projects. Andreas Nägele from DaimlerChrysler and Dr. Udo Brockmeyer from OSC Embedded Systems AG reported on their joint development project, the Stateflow Verification Environment.

Whatever part of the V-cycle you are involved in, as the presentations showed, you also need to see the big picture, and be aware of the other development steps. Just how successfully dSPACE tools are facing these challenges was illustrated in the papers given on the afternoon of day two, when the main focus was on using several dSPACE tools within the development process. First, Cord Elias from The MathWorks provided an overview of model-based design using MATLAB®/Simulink®. The modern development process for control systems for all-wheel systems in passenger vehicles at the Austrian company Magna Steyr Fahrzeugtechnik was the topic of Renato Mandic's paper. The contribution from Michael Bauermeister of Toyota Motorsport dealt with several aspects of the design process for software development in Formula One. Dr. Uwe Creutzburg presented the procedural model used at Continental AG for multiuser and multiproject development employing MATLAB/Simulink and TargetLink. All the speakers welcomed questions, and keen participation from the audience ensured lively discussion both inside and outside the sessions.

Presentation of dSPACE Developments

dSPACE also took the opportunity to show the audience its own innovations and further developments: AutomationDesk, for test automation, the dSPACE Calibration System for ECU calibration, and the new version of the TargetLink production code generator. The motivation for all these new



▲ *The evening program included blackjack and French roulette. All the thrills of the casino with plenty of style and music.*

developments is the desire to provide efficient, documentable processes and to support large development teams. An exhibition, which was open throughout the conference gave participants a further opportunity to gather comprehensive information.

On the evening of the first conference day, the adjacent "Alte Reithalle Stuttgart" provided a stylish venue for the participants to continue their talks in a relaxed atmosphere, while enjoying culinary delicacies and all the thrills of a casino. Astronomical sums of toy money were gambled and won, and sometimes lost, at blackjack and French roulette.

With attendance figures increasing each time the conference is held, this very positive feedback demonstrates that the dSPACE User Conference has become something of an institution.

Our thanks go to all the speakers and participants for their interest in the conference. For those who were unable to attend, the majority of papers can be found on our Web site, at www.dspace.de.



◀ *Plenty of time to get to know people and swap experiences.*

Third User Conference in Japan

The dSPACE User Conference in Tokyo was held on November 26, 2002. Over 230 attendees participated to exchange their knowledge and experience with other experts and inform themselves of the latest product developments at dSPACE.

Following an introduction on the current dSPACE development strategy and situation, three products that will enhance the standard V-cycle this year were presented. TargetLink 2.0, the automatic production code generator, provides a wide range of new features, such as support of the OSEK/VDX operating system standard and an integrated data dictionary. The new test automation tool, AutomationDesk, is impressive with comprehensive data management mechanisms and graphical design capabilities for test sequences throughout the entire development process. The dSPACE Calibration System, the new tool for calibrating electronic control units and acquiring measurement data, is a major addition for all stages of development.



▲ *The participants listened intently to the development experts, who welcomed questions and comments on their applications.*

different development steps of the V-cycle. Shigeaki Kakizaki, who works in the field of engine electronic control units at Nissan, gave insight into the current development situation there, showing how they use dSPACE Prototyper, TargetLink and dSPACE Simulator as standard tools. He concluded by emphasizing that function prototyping with MicroAutoBox has reduced their development effort by up to a half.

Mitsunobu Fukuda, from the four-wheel drive train application group at Nissan, expressed his satisfaction with the efficient use of MicroAutoBox, which saved half of the development time compared to prior approaches. The four-wheel drive train is based on a hybrid system and MicroAutoBox-controlled power distribution from motor and generator.

Lev Vitkin presented the utilization of code generation in control applications at Delphi Delco Electronics Systems, USA. To improve the quality of the products and minimize its development cycle, the company is adopting algorithm modeling and code generation techniques with TargetLink.

In the model-based development environment, Denso successfully uses the en-DYNA engine model from TESIS and dSPACE Simulator for their engine applications. Yasuhiro Inaba very much appreciated that the engineers from dSPACE's representatives in Japan (LinX Corporation) supported Denso by providing a turn-key hardware-in-the loop solution and sharing know-how in setting up the simulator. This project was successfully completed at the end of 2002.

We would like to express our thanks to all speakers and participants and look forward to the next conference in about a year's time.



▲ *Japanese users appreciated the opportunity to get first-hand information about upcoming product releases.*

Job Opportunities



Are you an engineer who is just graduating? Or are you looking for new professional challenges? Then come and join our team in Paderborn, Munich or Stuttgart, Germany; Paris, France; Cambridge, United Kingdom or Novi, MI, USA! Due to our continuous growth, dSPACE is looking for engineers in

- Software Development
- Hardware Development
- Applications
- Technical Sales
- Product Management

For more detailed information, please refer to www.dspace.de.

Training



For more details, please visit www.dspace.de or check the corresponding field on your response card. Further dates available on request:

- dSPACE Systems
- ControlDesk Basics
- ControlDesk Advanced
- Test Automation
- HIL Simulation
- TargetLink

Events



EUROPE

Embedded World 2003

February 18-20, Nuremberg, Germany
Messe Nuremberg, Hall 12
Booth #438

ASIM 2003

March 10-11, Ulm, Germany

Volkswagen Zuliefererbörse

March 28, Wolfsburg, Germany
CongressPark Wolfsburg, Hall 4
Booth #B405

RTS Embedded Systems 2003

April 1-3, Paris, France
Porte de Versailles, Hall 3
Booth #19

Embedded Systems Show 2003

May 14-15, London, United Kingdom
ExCel London
Booth #430

PCIM 2003

May 20-22, Nuremberg, Germany
Messe Nuremberg, Hall 12
Booth #424

USA

SAE Congress

March 3-6, Detroit, MI
Booth #1601

For more details, please visit www.dspace.de.

Australia

CEANET Pty Ltd.
Level 1, 265 Coronation Drive
Milton
Queensland 4064
Tel.: +61 7 3369 4499
Fax: +61 7 3369 4469
info@ceanet.com.au
www.ceanet.com.au

India

Cranes Software Intern. Ltd.
29, 7th Cross, 14th Main
Vasanthanagar
Bangalore - 560 052
Tel.: +91 80 2381 740
Fax: +91 80 2384 317
info@cranessoftware.com
www.cranessoftware.com

Korea

Darim Systems Co., Ltd.
Expo VentureTown 3rd Fl.
DoRyong-Dong 3-1
YuSung-Gu
Taejon
Tel.: +82 431 260 4747
Fax: +82 431 260 4748
info@darimsystems.co.kr
www.darimsystems.co.kr

Sweden

FENGCO Real Time Control AB
Hallonbergsplan 10
Box 7068
SE-174 07 Sundbyberg
Tel.: +46 8 6 28 03 15
Fax: +46 8 96 73 95
sales@fengco.se
www.fengco.se

China

China HiRain Tech. Co. Ltd.
Shangfang Plaza No. 27
Room 620
Bei San Huan Zhong Lu
100029 Beijing, P.R. China
Tel.: +86 10 82 02 19 50
Fax: +86 10 62 07 36 00
www.hirain.com

Israel

Omikron Delta (1927) Ltd.
10 Carlebach St.
Tel-Aviv 67132
Tel.: +972 3 561 5151
Fax: +972 3 561 2962
info@omikron.co.il
www.omikron.co.il

Netherlands

TSS Consultancy
Rietkraag 37
NL-3121 TC Schiedam
Tel.: +31 10 2 47 00 31
Fax: +31 10 2 47 00 32
info@tsscon.nl
www.tsscon.nl

Taiwan

Scientific Formosa Incorporation
11th Fl. 354 Fu-Shin N. Road
Taipei, Taiwan, R.O.C.
Tel.: +886 2 2505 05 25
Fax: +886 2 2503 16 80
info@sciformosa.com.tw
www.sciformosa.com.tw

Czech and Slovak Republic

HUMUSOFT s.r.o.
Novákových 6
180 000 Praha 8
Tel.: +420 2 84 01 17 30
Fax: +420 2 84 01 17 40
info@humusoft.cz
www.humusoft.cz

Japan

LinX Corporation
1-13-11 Eda-nishi
Aoba-ku, Yokohama-shi
Kanagawa, 225-0014 Japan
Tel.: +81 45 979 0731
Fax: +81 45 979 0732
info@linx.jp
www.linx.jp

Poland

ONT
ul. Obozna 11
30-011 Kraków
Tel.: +48 12 632 32 60
Fax: +48 12 632 17 80
info@ont.com.pl
www.ont.com.pl

Headquarters in Germany

dSPACE GmbH
Technologiepark 25
33100 Paderborn
Tel.: +49 52 51 16 38-0
Fax: +49 52 51 6 65 29
info@dspace.de
www.dspace.de

France

dSPACE Sarl
Parc Burospace
Bâtiment 17
Route de la plaine de Gisy
91573 Bièvres Cedex
Tel.: +33 1 6935 5060
Fax: +33 1 6935 5061
info@dspace.fr
www.dspace.fr

USA and Canada

dSPACE Inc.
28700 Cabot Drive · Suite 1100
Novi · MI 48377
Tel.: +1 248 567 1300
Fax: +1 248 567 0130
info@dspaceinc.com
www.dspaceinc.com

United Kingdom

dSPACE Ltd.
2nd Floor Westminster House
Spitfire Close · Ermine Business Park
Huntingdon
Cambridgeshire PE29 6XY
Tel.: +44 1480 410700
Fax: +44 1480 410701
info@dspace.ltd.uk
www.dspace.ltd.uk

